

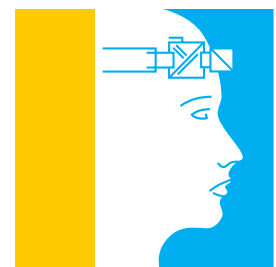

PACT^{ware}
Efficient configuration



PACT^{ware}[™]



PACTware – One configuration tool for all instruments

PACTware is a manufacturer and fieldbus-independent software for the operation of field instruments.

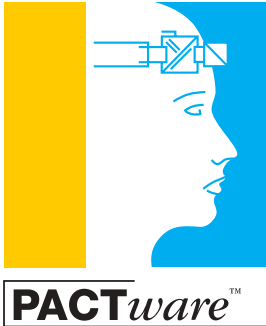

Open for all

PACTware is an open platform in which individual manufacturers can integrate the operation of their field instruments. Contrary to the idea of describing the instruments via a text file (Device Description), PACTware uses a standardized interface for instrument operation between the

frame program and the individual software modules. This allows modern and user-friendly adjustment concepts to be realised.

Optimum adjustment functions

In the PACTware concept, optimum instrument adjustment takes top priority. The uniform interface enables the use of the best possible adjustment concepts: optimised to fulfil user requirements and detached from the inflexible restrictions of superordinate software.

Communication independent

PACTware distinguishes between software modules for actual instrument adjustment and modules

for communication. This enables communication to be carried out through any type of communication. Already now, PACTware supports all common communication protocols. At the same time, these structures allow the integration of future standards.

Versatile

Each plant is different. PACTware can be implemented in many different places in a plant: from the central engineering station to on-site adjustment in the field. For the first time, it is possible to carry out parameter setting and configuration of all field instruments and field buses of a plant with only one engineering tool.

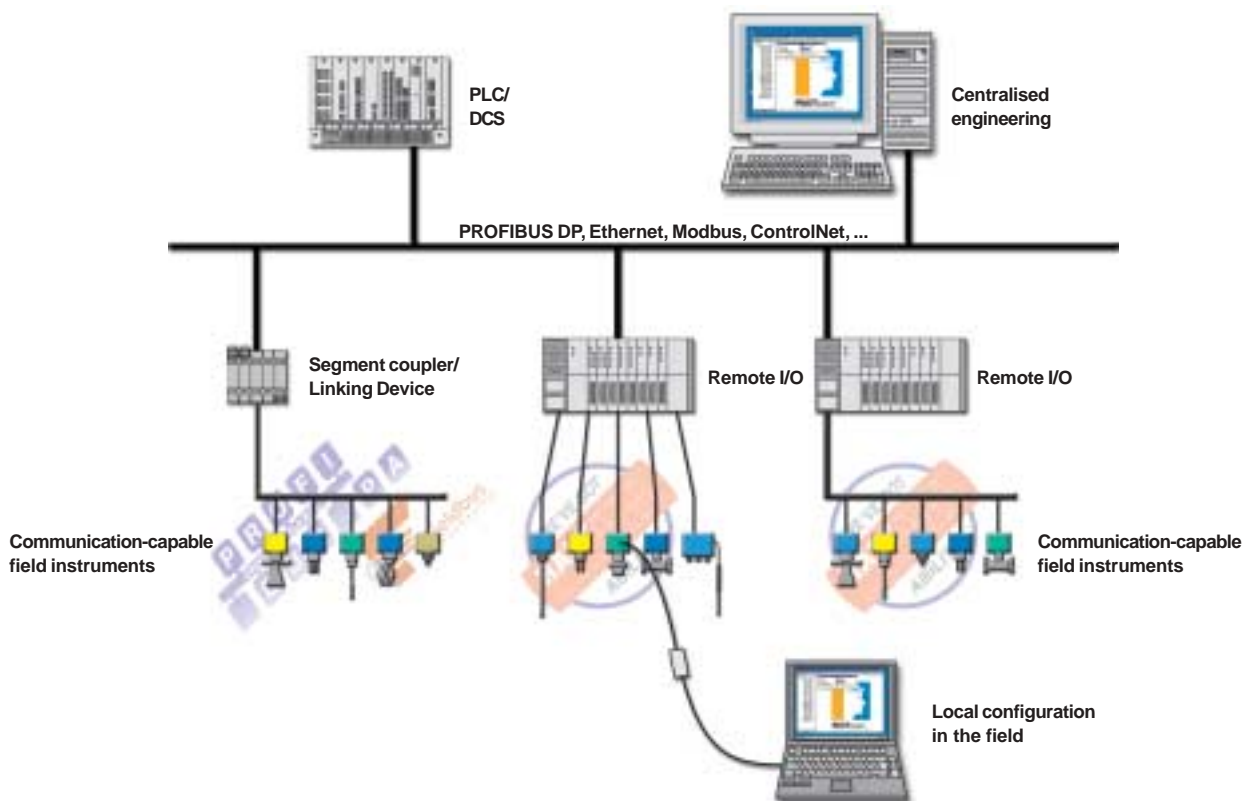

PACTware – based on FDT and DTM technology

PACTware based on FDT technology. This technology specifies the exchange of data between the system level and the field instruments.



Field Device Tool (FDT)

FDT is the name of an interface specification. The easiest way to explain the technology is by using an example from the office world: if a new device such as e.g. a printer is installed under Windows, it is done by installing a suitable driver. This printer

driver (device driver) is device and manufacturer-specific and comes with the printer. The device provides its own user interface.

Communication between operating system and printer takes place via predefined interfaces.

Plug & Play in automation

The FDT concept transfers this idea to the world of automation: each communicating field instrument has an electronic device description that can be integrated into the world of the system. That is, into the configuration and adjustment tools of a system environment, as well as into the stand-alone tool PACTware.

No new description language

The heart of this concept is that no new description language needs to be defined, but rather the interface between the tool and the description object of an instrument. This makes the concept independent from the actual (field bus) communication itself.

Device Type Manager (DTM)

Like the printer driver in the office world, the field instrument brings its own driver, including user interface, into the FDT world. This driver is called Device Type Manager, in short, DTM. It comprises all data and functions of the field instrument. A DTM can cover only one instrument type, or in some cases a complete family of instruments.

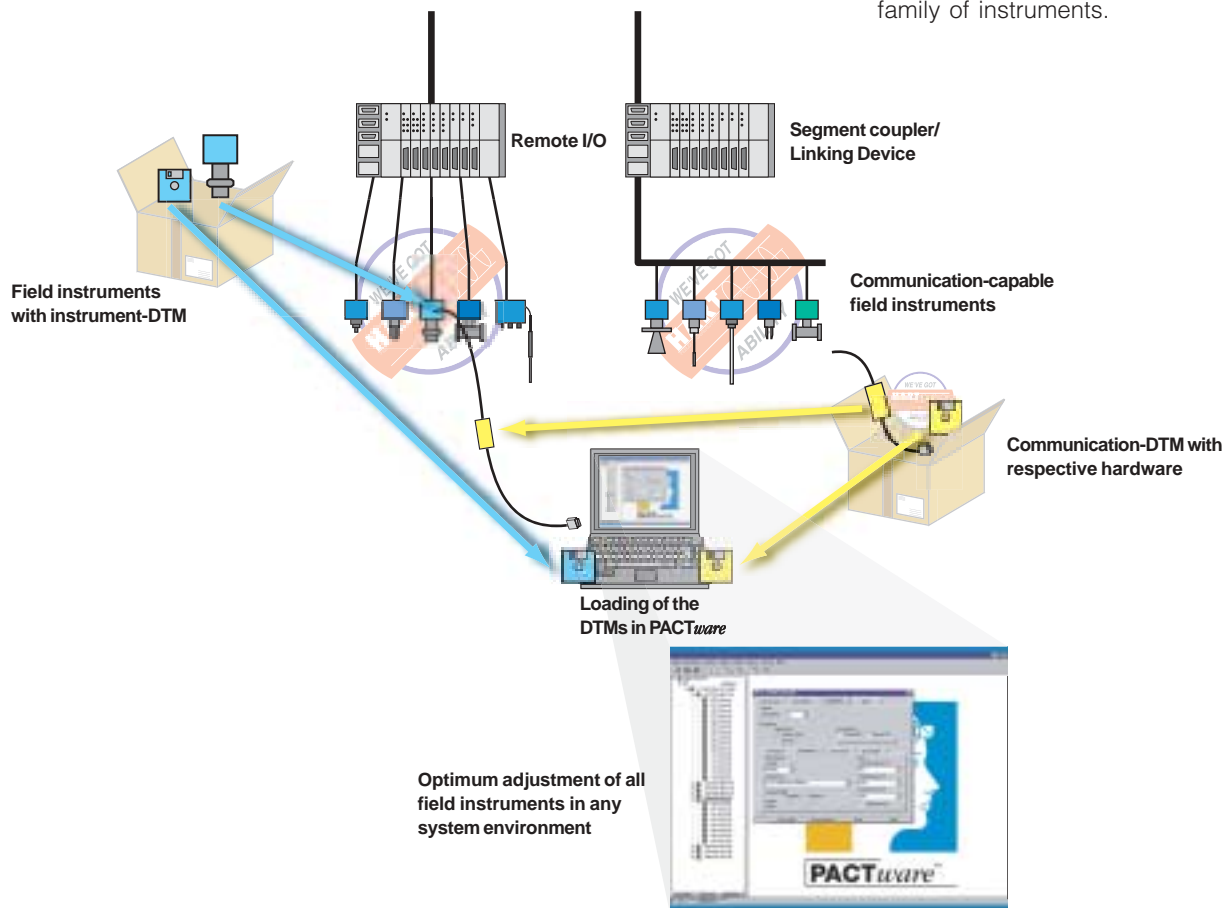

PACTware – Easy and efficient configuration

With PACTware all instruments of a plant can be quickly and easily configured, set up and if necessary, diagnosed. Universal use.

Unlimited possibilities

Whereas a usual Device Description (DD) can be just an inflexible description of instrument functionality, a DTM has almost no limitations with regard to presentation and user guidance. Adjustment of all available instrument functions, perfectly adapted to the user's requirements, is thus possible. And: DTM technology allows the same instrument adjustment procedures to be used in any FDT environment.

Beside instrument DTMs, there are also DTMs for communication devices, such as e.g. PROFIBUS DP cards or HART modems. The linking, administration and assignment of the DTMs is done by PACTware.

Quick and easy

The handling of PACTware is really easy. To begin with, all the instruments of a plant, including communication drivers, are assembled into one project. The corresponding instruments are simply fetched from a device catalogue via drag-and-drop and inserted into the project. After this is done, the structure of the system is transparent and clearly defined. From here, each individual instrument and communication component can be directly accessed:

- to adapt the configuration
- to modify individual parameters
- to simulate individual functions
- to get a detailed, meaningful diagnosis
- to prepare documentation

And all of this is manufacturer and communication-independent. Needless to say, subsequent modifications and extensions of the structure can always be carried out.

Proven, available technology

PACTware as stand-alone tool and the corresponding DTMs have already been successfully used for many years. In spite of that, an appropriate DTM for every instrument of every supplier is not yet available. By means of the so-called DD compiler, it is now possible to automatically generate a simple, but fully functioning DTM from the device description (DD) of a HART



instrument. Conversion tools for PROFIBUS and FF instrument descriptions are in preparation. This guarantees wide availability within a short time.

PACTware

- simplifies set-up in automation
- supports the complete functionality of the field instruments
- is prepared for future standards, such as e.g. Ethernet
- unifies the instrument world
- is future-proof

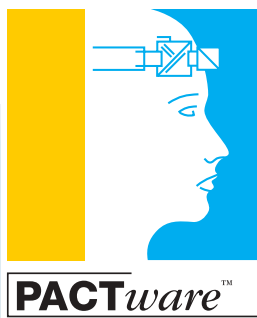



Configuration

PACTware allows the configuration of a complete system. In the process, an online connection is not compulsory. Thus, for example, topology planning as well as structuring and configuration of the implemented system components can be carried out in offline mode.

Parameter adjustment

Instruments and systems are adjusted with PACTware by means of point-to-point communication or via a bus system. Easy handling has top priority. No difficult installation or complex topology planning is necessary. Fast readout of device information, as well as reliable writing of modified settings into an instrument, is assured. This is typically applied in the workshop or in the field.

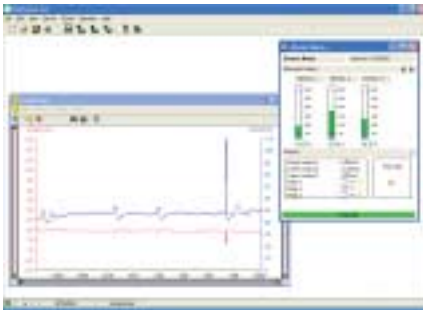

Simulation

During the set-up phase, the signal flow within an application can be checked by simulating a certain process value. Signals can thus be traced over different measurement points and faults corrected at an early stage.

Diagnostics

For the analysis of faults in the system or in the field instruments, suitable tools are available in the installed DTMs in PACTware. For example, short-term faults can be detected by means of the graphical presentation of measured values. Or to realise long-term observation of data, measured values can be recorded over an unlimited period of time.



Documentation

An overview of the project as well as the set values of individual instruments can be conveniently printed out with PACTware. Furthermore, all necessary information such as device description, manufacturer identification, order number, serial number and firmware version are available in the DTM. Time-consuming searches for up-to-date documentation thus belong to the past.

PACTware – Simply download and take off

The free-of-charge adjustment software PACTware can be downloaded anytime from the Internet and, with the appended DTMs, immediately used to adjust any HART instrument.

PACTware Consortium e.V.

More and more companies support the PACTware idea and use its technology. With a lean organisation the PACTware Consortium e.V. joins mutual interests and advances the concept as well as the product. For example by actively contributing to the FDT specification, by integrating additional field busses and by extending Asset Management functionality.

The association is the custodian of PACTware and has proprietor rights. New developments and extensions are co-ordinated by the association, and new versions are created and released via a painstaking process. The result is an up-to-date, manufacturer-independent software for instrument operation in automation.



Distribution of PACTware

The association takes care of development and maintenance of the software, while the individual member companies distribute PACTware together with their own DTMs on the market. This is ideal for the user, because it means he always has the same contact: for the actual field instrument, for its device driver (DTM), and for the frame application PACTware. And of course service and support for any one of these components also comes from the one provider.

Adjustment of HART instruments included

The PACTware basic package already enables adjustment of any HART instrument. It contains a communication driver for standard HART-FSK modems and a generic HART instrument DTM that allows easy adjustment of the basic parameters of any HART instrument.

Download free of charge

The easiest way to get PACTware is to download it from the Internet pages of the member companies. A clear and up-to-date list of the members who offer the download can be viewed on the homepage of the PACTware consortium under www.pactware.com.

Much additional information on the topic of FDT can be found on the pages of the individual members. Many instrument manufacturers also offer as downloads free-of-charge DTMs for the adjustment of their instruments. There's really no easier way to check out for yourself the advantages of FDT/DTM technology and PACTware.

Prepared for the future

Thanks to the clear and open-ended structures, integration of all present and future field busses is possible anytime. But PACTware offers more: via additional interfaces, more functions – available to all DTMs – can be integrated into PACTware. These so-called “Plug-Ins” enable, for example, Audit Trail or Trending of a large number of instruments. With PACTware, the data of all communication components and field instruments are available centrally. This is the prerequisite for plant-wide Asset Management.

One for all

A DTM written for PACT*ware* can be implemented one-to-one in any other FDT environment. Instrument manufacturers thus have to maintain only one software component for instrument adjustment and can focus on their key business: instrument development. For the user, this not only assures consistent instrument adjustment and functionality, regardless of system architecture or frame application – it also guarantees high software quality, and thus high availability of the entire plant.



High software quality

Linux is demonstrating this in the world of the office – PACT*ware* in the world of automation: the software is Open Source and is available as source code to full members of the PACT*ware* Consortium e.V. This transparency guarantees high software quality. Any bugs that appear can be easily and quickly localised, and above all, eliminated. Fewer dependencies on individual companies arise. That's because all companies of the PACT*ware* consortium guarantee the same uncompromising support and development of PACT*ware*. That assures real interoperability and the best possible technology for state-of-the-art applications.

The advantages at a glance

PACT*ware* is a manufacturer and field bus-independent software for the operation of field instruments. It makes the configuration of widely differing instruments in any automation environment possible with only one software tool.

PACT*ware*

- fits in any automation environment
- is the platform for all DTMs acc. to FDT standard
- allows adjustment of all field instruments via any communication structure
- is free of charge and continues to be developed

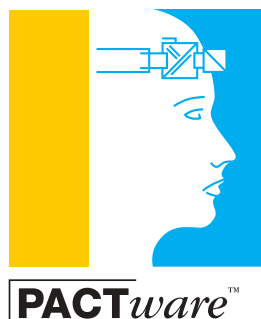



The AS-i Master Company



People for Process Automation



Prozessautomation



The members – Field device manufacturers

Bihl + Wiedemann GmbH, D-68199 Mannheim
www.bihl-wiedemann.de

Bopp & Reuther Messtechnik GmbH, D-67346 Speyer
www.burmt.de

Bürkert GmbH & Co. KG, D-74653 Ingelfingen
www.buerkert.com

Endress + Hauser Process Solutions AG, CH-4153 Reinach
www.endress.com

Invensys Systems, Inc., Foxboro, MA 02035 USA
www.foxboro.com

Knick Elektronische Messgeräte GmbH & Co. KG, D-14163 Berlin
www.knick.de

KROHNE Messtechnik GmbH & Co. KG, D-47058 Duisburg
www.krohne.de

Pepperl+Fuchs GmbH, D-68307 Mannheim
www.pepperl-fuchs.com

SAMSON AG Mess- und Regeltechnik, D-60314 Frankfurt
www.samson.de

Trebing & Himstedt Prozessautomation GmbH & Co. KG, D-19061 Schwerin
www.t-h.de

Hans Turck GmbH & Co. KG, D-45472 Mülheim an der Ruhr
www.turck.com

VEGA Grieshaber KG, D-77761 Schiltach
www.vega.com

WIKA Alexander Wiegand GmbH & Co. KG, D-63911 Klingenberg
www.wika.de

YOKOGAWA Industrial Automation Business Div., Tokyo, 180-8750 Japan
www.yokogawa.com

The members – PACTware Solution Provider

CodeWrights GmbH, D-76137 Karlsruhe
www.codewrights.biz

FS SOFT, D-56348 Kestert
www.fssoft.net

ICS GmbH, D-76275 Ettlingen
www.icsgmbh.de

ifak – Institut für Automation und Kommunikation e.V. Magdeburg, D-39179 Barleben
www.ifak-md.de

Steinbeis Transferzentrum System- und Regelungstechnik, D-77656 Offenburg
www.stz-systemtechnik.de

The members – University

itm Technische Universität München, D-85747 Garching bei München
www.itm.tum.de

You will find an up-to-date overview of the members under www.pactware.com.



PACTware Consortium e.V.

Panoramastraße 16 • D-76327 Pfinztal
Phone (49) 7240 94309-61 • Fax (49) 7240 94309-63
info@pactware.com • www.pactware.com